

Setting up Your Digital-to-Analog Converter Box (for viewing analog and digital broadcasts)

Analog TVs can receive digital television (DTV) signals by using a “Digital-to-Analog Converter Box” that can be purchased at retail stores. If you wish to watch over-the-air programming with an antenna (such as “rabbit ears” on your TV or an antenna on your roof) from stations that broadcast in digital (such as full-power stations) **and** stations that broadcast in analog (such as low-power, Class A or TV translator stations), you should choose one of the following options:

Option 1) Purchase a Converter Box that has “analog pass-through” capability and install it using our “Basic Set-Up” guide. The FCC’s Basic Set-Up guide is available at www.fcc.gov/guides/digital-analog-converter-box-setup-basic.

Or;

Option 2) Purchase any Converter Box and use either of the following set-ups.

Set-up #1: Your TV has “Audio/Video In” (A/V In) ports:

Supplies: You will need your analog TV, the antenna you have been using (indoor or outdoor), and the coaxial wire that currently connects your antenna to your TV (as pictured on the far right). Your new Converter box will come with a second coaxial wire, a set of A/V cables (three wires with red, white and yellow plugs), and a remote control. If you do not already have them, you will also need to purchase a third coaxial wire and a 2-way splitter. Before you begin you should unplug your TV.

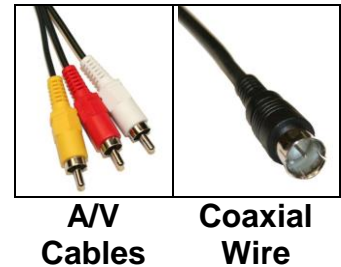

Step 1 Unplug the coaxial antenna wire (wire #1) from your TV “Antenna In (RF)” port.

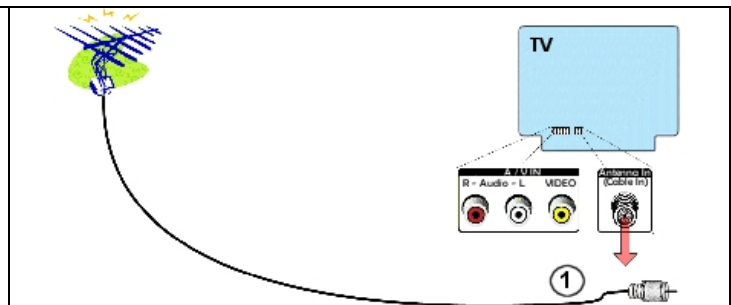

Step 2 Plug wire #1 into the "In" port on your 2-way splitter.
 Step 3 Using a second coaxial wire (wire #2), plug one end into one of the "Out" ports on the 2-way splitter. Plug the other end into the "Antenna In (RF)" port on your TV set.
 Step 4 Using a third coaxial wire (wire #3), plug one end into the other "Out" port on the 2-way splitter. Plug the other end into the "Antenna In (RF)" port on your Converter Box.

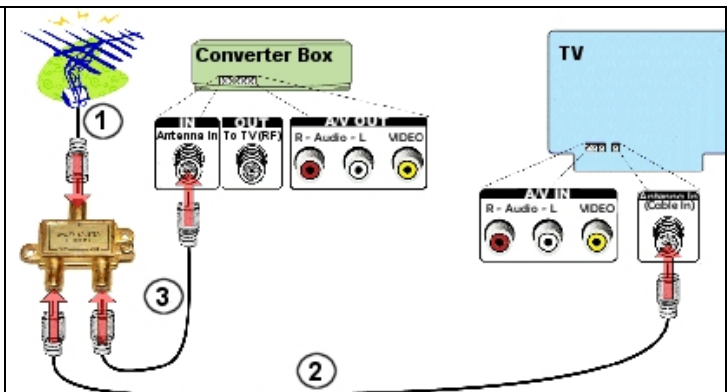

Step 5 Using a set of A/V cables, plug one end of the cables into the "A/V Out" ports on the Converter Box. Match the colors of the plugs to the colors of the ports, so that red plugs into red, white into white, and yellow into yellow. Plug the other end of the cables into the "A/V In" port on your TV set in the same way. If your TV does not have a red port, leave that cable unplugged on both ends.

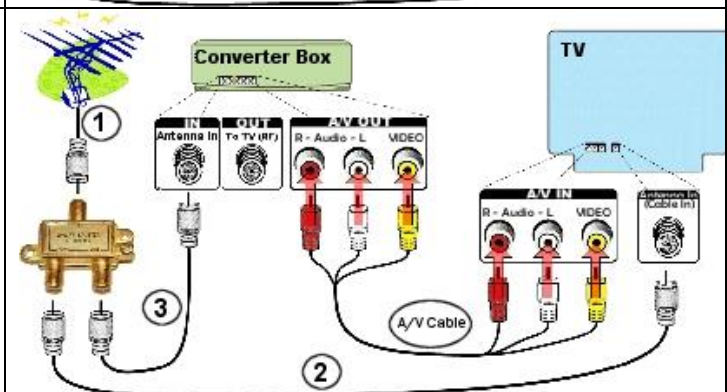

Step 6 Plug the power cords on your Converter Box and TV into a power outlet, and turn on your TV and Converter Box. To watch digital broadcasts, set your TV to "Video In." Using the remote control that came with your Converter Box, follow the on-screen set-up guide to scan for available DTV channels, and begin enjoying the benefits of Digital Television! You will be able to access all available digital broadcasts through your converter box and its remote control. To watch analog broadcasts, set your TV to "TV In." You will be able to access all available analog broadcasts through your TV's remote control.

Set-up #2: Your TV has only an "Antenna In" port:

Supplies: You will need your analog TV, the antenna you have been using (indoor or outdoor), and the coaxial wire that currently connects your antenna to your TV (as pictured on the right). Your new Converter box will come with a second coaxial wire and a remote control. If you do not already have them, you will also need to purchase three additional coaxial wires (for a total of five), a 2-way splitter, and an A/B switch. Before you begin you should unplug your TV.



Coaxial Wire

Step 1 Unplug the coaxial antenna wire (wire #1) from your TV "Antenna In (RF)" port.

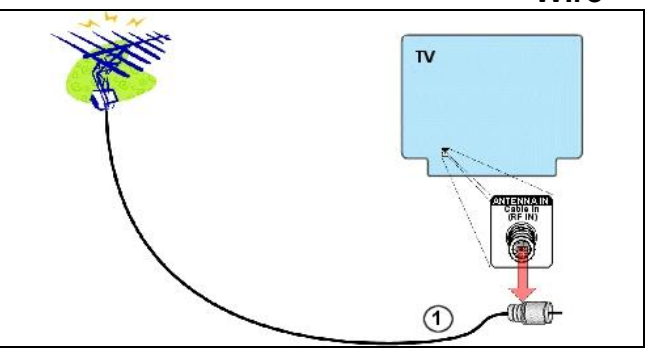

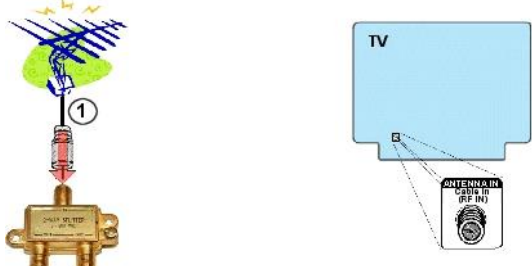
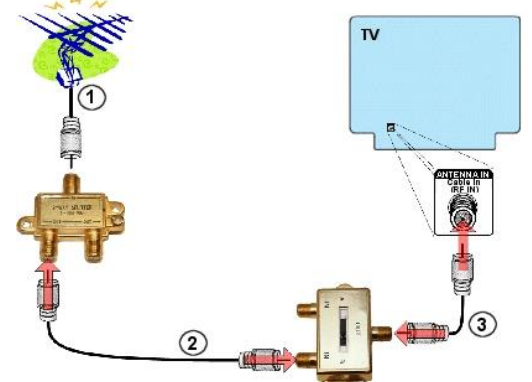
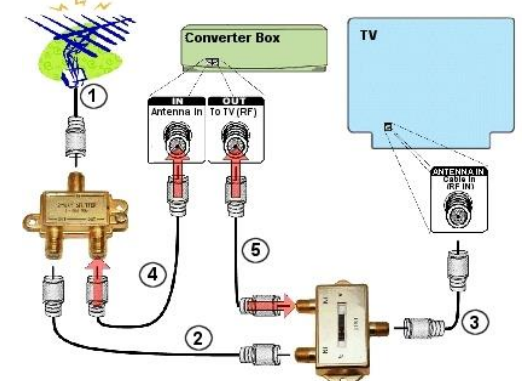
| | |
|---|---|
| <p>Step ② Plug wire #1 into the “In” port on your 2-way splitter.</p> |  |
| <p>Step ③ Using a second coaxial wire (wire #2), plug one end into one of the “Out” ports on the 2-way splitter. Plug the other end into the “In B” port on the A/B switch.</p> <p>Step ④ Using a third coaxial wire (wire #3), plug one end into the “Out” port on the A/B switch. Plug the other end into the “Antenna In (RF)” port on your TV set.</p> |  |
| <p>Step ⑤ Using a fourth coaxial wire (wire #4), plug one end into the other “Out” port on the 2-way splitter. Plug the other end into the “Antenna In (RF)” port on your Converter Box.</p> <p>Step ⑥ Using a fifth coaxial wire (wire #5), plug one end into the “Out to TV (RF)” port on your Converter Box. Plug the other end into the “In A” port on the A/B switch.</p> |  |
| <p>Step ⑦ Plug the power cords on your Converter Box and TV into a power outlet, and turn on your TV and Converter Box. Set the A/B switch to position “A” and tune your TV to channel 3 (or 4) to watch digital TV. Using the remote control that came with your Converter Box, follow the on-screen set-up guide to scan for available DTV channels, and begin enjoying the benefits of Digital Television! To watch analog TV, set the A/B switch to position “B” and change the channel on your TV set.</p> | |

- If your Converter Box includes a “universal remote control” or you already have your own universal remote control, follow the instructions that come with your Converter Box to program the remote to work for both the TV and the Converter Box.
- For instructions on connecting your converter box to other components such as a VCR or a DVD player, go to www.fcc.gov/digital-television or contact the FCC by calling 1-888-CALL-FCC (1-888-225-5322) voice or 1-888-TELL-FCC (1-888-835-5322) TTY.

Consumer Help Center

For more information on consumer issues, visit the FCC's Consumer Help Center at www.fcc.gov/consumers.

Accessible formats

To request this article in an accessible format - braille, large print, Word or text document or audio - write or call us at the address or phone number at the bottom of the page, or send an email to fcc504@fcc.gov.

Last Reviewed: 10/28/16

